

L Feet 18 หินา 6 mm

ชุดจับยึดหลังคาเมทัลชีทและกระเบื้องลอนคู่

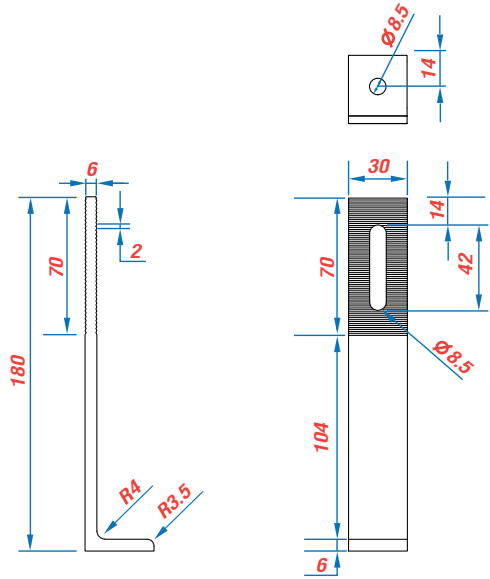

รายละเอียดอุปกรณ์ติดตั้งเพงโซลาร์เซลล์

รหัสสินค้า	C07
ชื่อสินค้า	L Feet 18
วัสดุ	อลูมิเนียม 6063
ค่าความแข็งของอลูมิเนียม	12-14 Rockwell
แรงดึง	1,316.46 แรงกิโลกรัม
น้ำหนัก	0.116 กิโลกรัม/ชิ้น
ขนาดบรรจุภัณฑ์	10 ชิ้น/ถุง ขนาดถุง 20x19x5 เซนติเมตร 200 ชิ้น/กล่อง ขนาดกล่อง 37x43x22 เซนติเมตร



TEST REPORT

Received No.: 68-11-020
Report No.: TGI-TS-003
Rev.: 00

Customer's company name: **PSI Corporation Co., Ltd.**
Address: **2 Soi Ramkhamhaeng 159, Rat Phatthana , Saphansung , Bangkok 10240 Thailand.**

Test Product:	-	Material Characterization:	-
Part Name:	L FEED 18	Standard of Test:	As Customer Request
Part No.:	01,02,03	Type of Test:	Tensile Testing
Lot No.:	-	Equipment / Serial No.:	Universal Testing Machine
Material Specification	-	Equipment's Capacity:	10 Tons
Received Date:	05 / Nov. / 2025	Ambient Temp.:	21.6 °C, 59 % RH
Tested Date:	06 / Nov. / 2025		

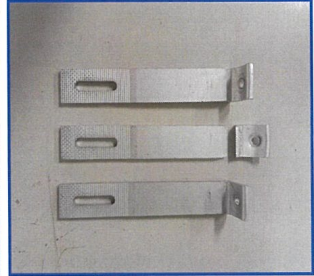
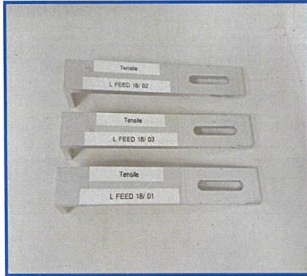

Result of Tensile test

Test No.	Max. Load (N)	Max. Load (kgf)
01	13,234.861	1,349.119
02	12,576.371	1,281.995
03	12,914.467	1,316.459

Operated by: *Chaiharong*
Testing Operator
Technical Team
(06 / Nov. / 2025)

Reviewed by: *[Signature]*
Mr.Kriangkrai Kaewko
Technical Manager
(06 / Nov. / 2025)

Approved by: *[Signature]*
Mr.Weerasak Thaotho
Quality Manager
(06 / Nov. / 2025)

Commentary:

- Our division and institute not allow to change, add or subtract anywhere on this report, except only in case of already accepted by writing from our division.
- Our division can not confess to any direct or indirect damage that will occur after this by using data, analysis results, results or conclusion in this report to design, produce or others.
- Experiment results are exactly true especially only on specimen that was carried to test.
- "Test marked * in this report are not included in the TISI Accreditation Schedule for our Laboratory"